

STATIC DIMENSIONS

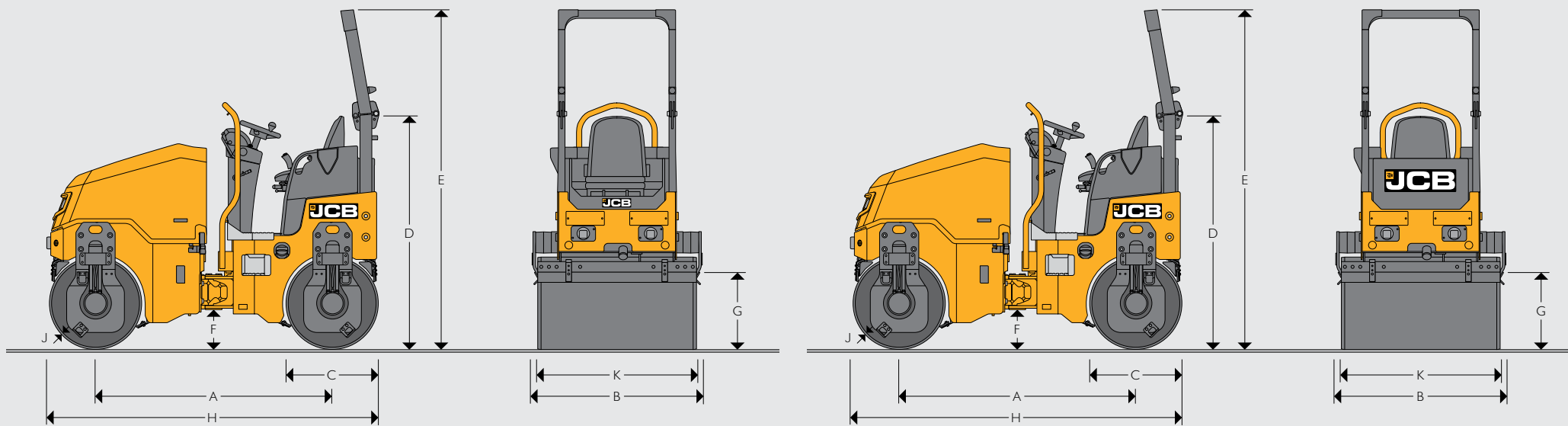

STATIC DIMENSIONS

			CT160-80	CT160-100	CT260-100	CT260-120
A	Wheelbase	mm	1560	1560	1790	1790
B	Overall width	mm	960	1090	1095	1295
C	Drum diameter	mm	580	580	700	700
D	Height to top of seat	mm	1650	1650	1755	1755
E	Height to top of ROPS	mm	2485	2485	2510	2510
F	Ground clearance	mm	255	255	270	270
G	Curb clearance	mm	510	510	560	560
H	Total travel length	mm	2140	2140	2490	2490
J	Drum thickness	mm	12	12	12	12
K	Drum width	mm	800	1000	1000	1200

OPERATING DATA									
	CT160-80		CT160-100		CT260-100		CT260-120		
Nominal weight	kg	1630		1710		2280		2420	
Operating weight (CECE)	kg	1710		1790		2420		2560	
Maximum operating weight	kg	1790		1870		2600		2740	
Operating weight front	kg	800		840		1190		1260	
Operating weight rear	kg	910		950		1230		1300	
Working width	mm	800		1000		1000		1200	
Operating linear load	kg/cm	10.0	11.4	8.4	9.5	11.9	12.3	10.5	10.9
Exciter frequency	Hz	50	66	50	66	50	66	50	66
Nominal amplitude	mm	0.47		0.41		0.56		0.51	
Centrifugal force (each drum)	kN	12.8	22.2	12.8	22.2	23.6	41.1	23.6	41.1
Max. Working speed	km/h	9		9		10		10	
Drum offset left / right - manual (option)	mm	56		56		60		60	
Steering angle	deg	±33		±33		±33		±33	
Oscillation angle	deg	±8		±8		±8		±8	
Inner turn radius	mm	2160		2090		2475		2375	
Gradeability with vibration up to	%	25		25		30		30	
Gradeability without vibration up to	%	35		35		40		40	

ENGINE		
	CT160 (All Models)	CT260 (All Models)
Make	Kubota	
Model	D1005-E4B-EU	D1703-M-DI-E4B
Type	3 cylinder, water-cooled four-stroke diesel engine	3 cylinder, water-cooled four-stroke diesel engine
Piston displacement	cm ³	1001
Performance	kW (hp)	14.5 (19.8)
Operating speed	rpm	2550
Starting device	Electric motor	Electric motor
Air cleaner	Dry cartridge + safety cartridge	Dry cartridge + safety cartridge
Fuel filler	Cartridge	Cartridge

PROPULSION
Hydrostatic with variable displacement pump and fixed displacement motors with direct drive to both drums = double drum drive.

EXCITER DRIVE
Electronically controlled hydrostatic direct drive on both drums for double vibration or single vibration front or rear, AVC (automatic vibration control).

EXCITER
Single-shaft circular exciter.

STEERING SYSTEM
Servo assisted, maintenance free centre articulation with oscillation facility.

SERVICE CAPACITIES		
	CT160 (All Models)	CT260 (All Models)
Fuel tank capacity	litres	33
Sprinkler water tank capacity	litres	100

BRAKING SYSTEM
Service brake: Hydrostatic propulsion system.
Parking brake: Hydraulically-released brake on both drums (SAHR).

WATER SYSTEM
Pressurised sprinkling system, adjustable scrapers (two each drum), changeable nozzles, multiple water filtering.

ELECTRICAL SYSTEM		
	CT160 (All Models)	CT260 (All Models)
Electrical system voltage	V	12
Battery capacity	Ah	62
Alternator	A	60

DRIVERS STAND / INSTRUMENTS
Fuel, battery charging current, sprinkler system, parking brake, hour meter, engine oil pressure, air filter condition, hydraulic oil level and temperature, water level indicator, cup holder, comfortable adjustable operator seat and safety belt, flashing amber beacon, fan guard, locking instrument panel cover, reverse alarm, foldable ROPs.

OPTIONS
Foldable ROPs Canopy, Road lights, Seat belt activated Green Beacon, White Noise Alarm, LED Work lights (not compatible with Canopy).